



Ski Carrier Installation Instructions

Package Contents:

- (2) Ski Carrier
- (4) Carriage Bolt
- (4) Rectangular Washer
- (4) 2-Wing Knob
- (4) Nylon Washers

1.

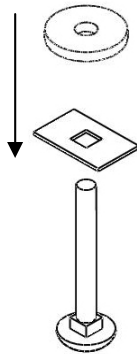

Slide the rectangular washer and nylon washer onto the carriage bolt. Repeat for all four carriage bolts.

2.

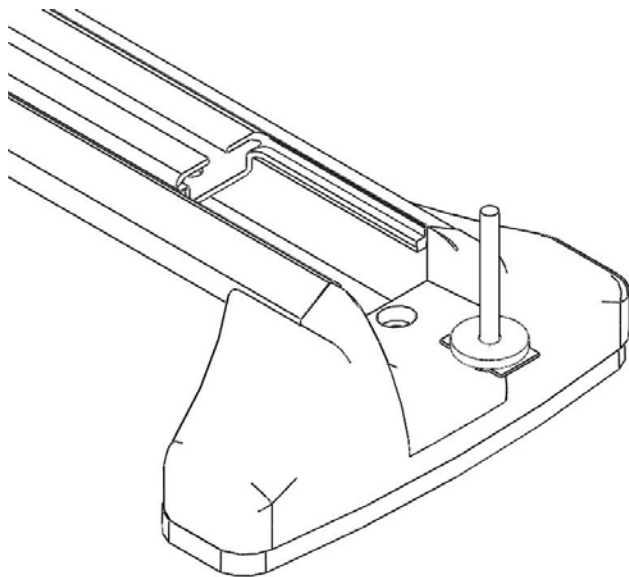

Remove the end cap from the track. Slide two carriage bolts with washers into each crossbar. Replace the end cap. Repeat for other crossbar.

3.

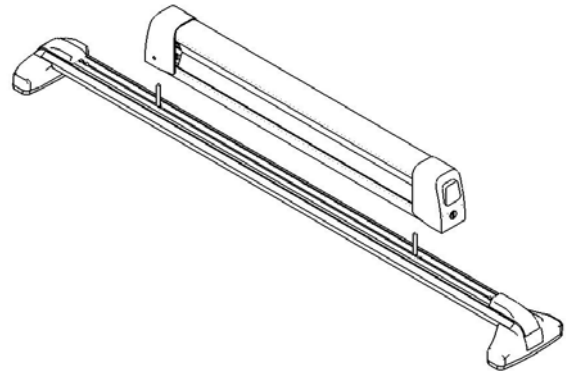

Position the two carriage bolts so that the bolts line up with the holes on the bottom of the ski carrier. Set the ski carrier down on the carriage bolts. Repeat for other crossbar.

4.

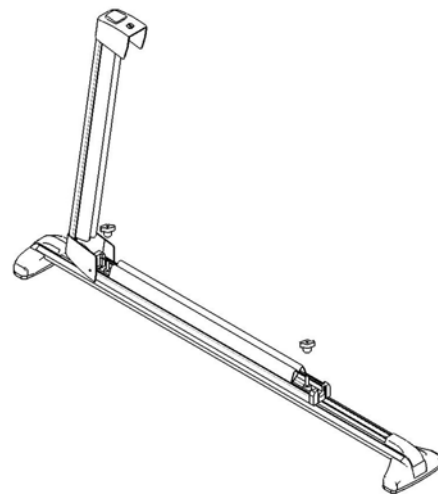

Open the upper arm of the ski carrier. Place 2-wing knobs onto the two carriage bolts and firmly tighten. Repeat for other crossbar.

5.

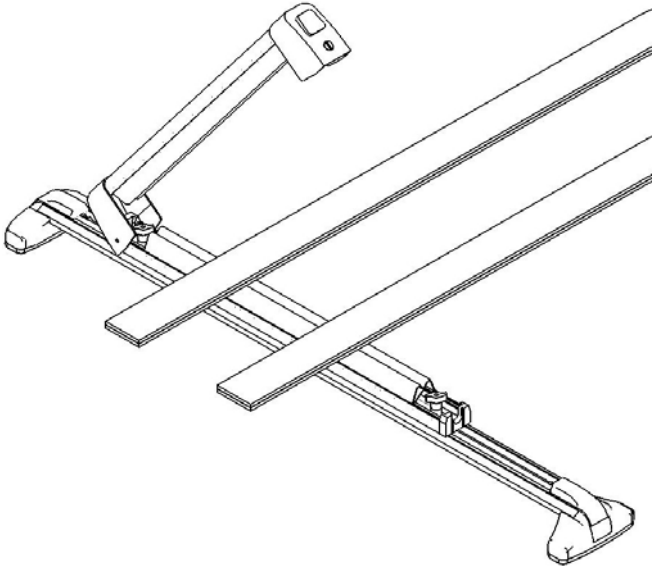

Before mounting skis, lower the upper arm until it stops at the position shown. Repeat for other crossbar. Mount the skis into the carrier with the tips facing to the rear.

6.

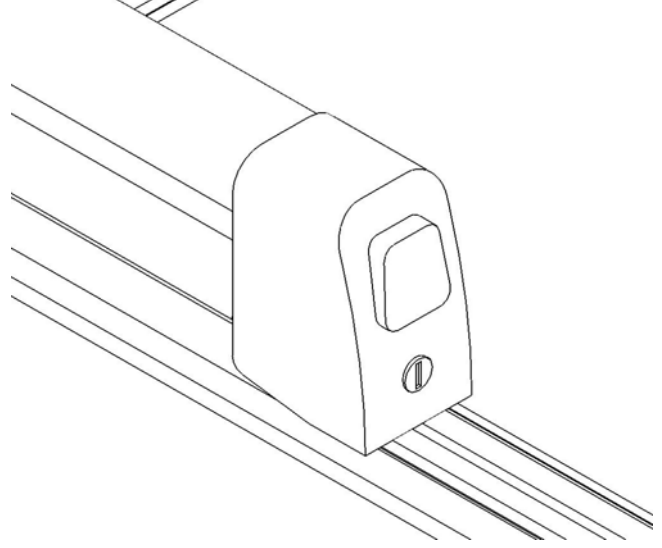

To close the ski carrier, push the hood down until the latch clicks securely. Repeat for other crossbar. The latch is designed with two settings to accommodate varying thickness of skis.

PRO RAC GUIDELINES

Please review the instructions and warranty carefully. Assembly and installation are the purchaser's responsibility and beyond ProRac's control. Therefore, ProRac exclusively limits its warranty to the repair or replacement of a defective ProRac product for up to three years from retail purchase. Warranty excludes damage to your vehicle, cargo, or any person or property during assembly, installation, and use.

- ◆ Do not carry more than 150 pounds (68KG) of combined cargo and accessories on ProRac crossbars. ProRac crossbars do not increase gutter or roof strength. ProRac cannot warranty loads that exceed this limit.
- ◆ Do not use ProRac crossbars and accessories for purposes other than those for which they were designed. Do not exceed their carrying capacity. Failure to follow these guidelines or the product instructions will void the warranty.
- ◆ Make sure all knobs, bolts, screws, straps, and locks are firmly attached, tightened, and locked before every trip. All fasteners must be periodically inspected for signs of wear, corrosion, and fatigue. Check your load at stops during long trips to ensure continued fastening security.
- ◆ Check all local and state laws governing projection of objects beyond the width and length of vehicle. Be aware of the width and height of your cargo since low-clearance branches, bridges, and parking garages can affect the load. Never drive with any lock, knob, or rack in an open or unlocked position. All long loads such as, but not limited to, sailboards, surfboards, kayaks, canoes, and lumber must be tied down front and rear to the bumpers or tow hooks of the vehicle.
- ◆ Remove your rack and accessories when they are not in use and before entering automatic car washes.
- ◆ All locks must be turned and moved periodically to ensure smooth operation. Use graphite or similar dry lubricant. Locks are designed to deter vandalism and theft. Remove valuable gear if your vehicle is unattended. Replacement keys are available only through your ProRac dealer.
- ◆ All cargo will affect the vehicle's driving behavior. For your safety, adapt your speed to the conditions of the road and load being carried. Obey all posted speed limits and traffic cautions.
- ◆ Due to their wind resistance, do not carry disks or wheels with covers on the ProRac bike carrier.
- ◆ Consult your ProRac dealer if you have questions regarding the operation and limits of ProRac products. Review all instructions and warranty information carefully.

© 2005 ProRac Systems, Inc.

FGAT724-IS
Revised 8-18-05

ProRac Systems Inc.
7109 31st Avenue North
Minneapolis, MN 55427-2848

Toll Free: 1-800-217-7133
Phone: 763-546-5620
Fax: 763-546-0933
WWW.PRORAC.COM