



Cargo Basket Installation Instructions

Package Contents:

- | | |
|------------------------------|----------------------|
| (2) Basket Assembly (halves) | (4) Crossbar Saddles |
| (4) Clamp Plates | (8) Threaded Knobs |
| (4) U Bolts | (2) Machine Screws |

1. Assemble Basket

Remove plastic end caps from outer frame tubes. Join two basket halves together and insert machine screws into the two holes in frame. Tighten screws.

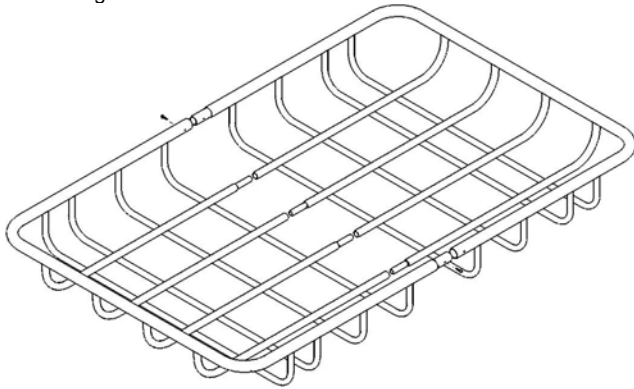

2. Attach Crossbar Saddles

Snap crossbar saddles into place per diagram. Make sure the saddles are securely attached to the basket tubular frame.

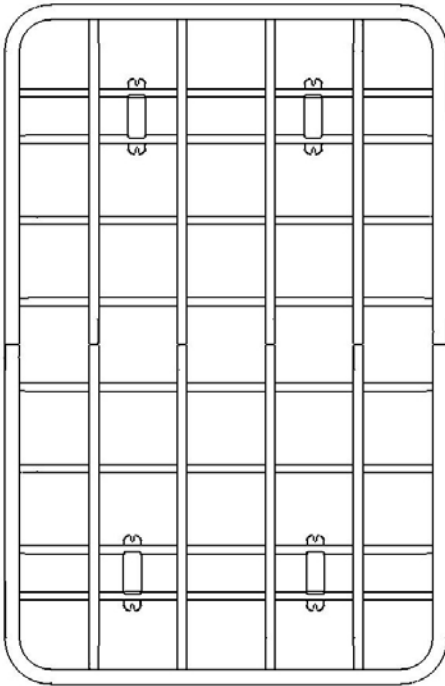

3. Determine Crossbar Spacing

Crossbars will need to be adjusted to accommodate spacing of the cargo basket mounting saddles. If necessary, adjust crossbars so that the basket mounting saddles line up with the crossbars.

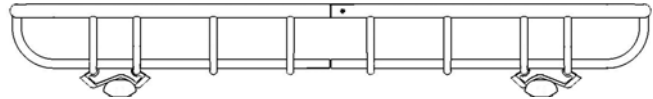

4. Mount Cargo Basket

Attach the Cargo Basket to the crossbars by placing a U-Bolt around the crossbar and up through the mounting saddle. Make sure that the U-Bolt is inserted securely into the mounting saddle. Place a clamp plate over the two threaded ends of the U-Bolt (see diagram). Place a knob on each U-Bolt shaft and tighten. Make sure that knobs are thoroughly tightened and that the basket is secure on the crossbars.

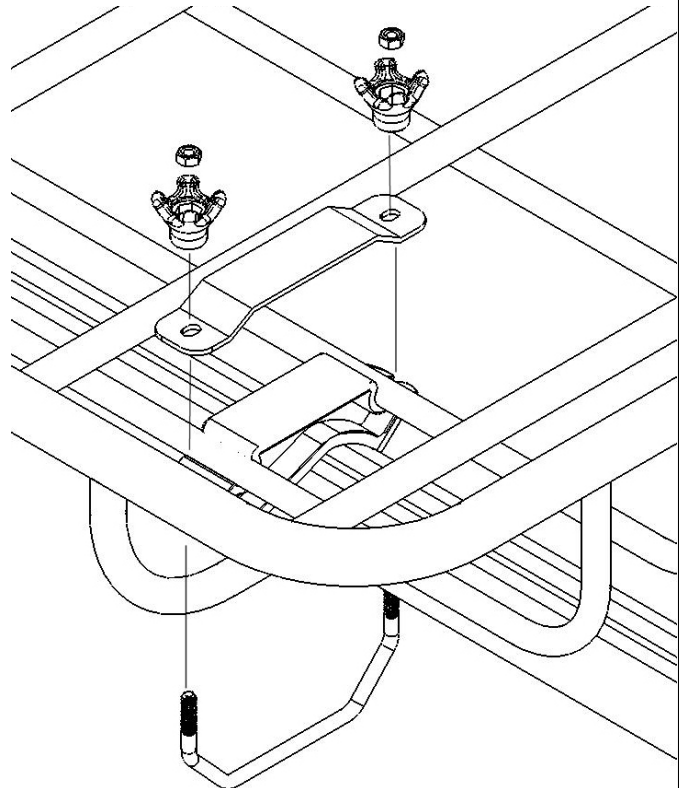

5. Positioning and Loading the cargo basket

Position the Cargo Basket centered on the crossbars if possible. If using other accessories with the cargo basket, adjust positioning to evenly distribute the load over the crossbar span. Make sure all items are properly secured. Do not overload the basket. Periodically check knobs for tightness, retighten if necessary.

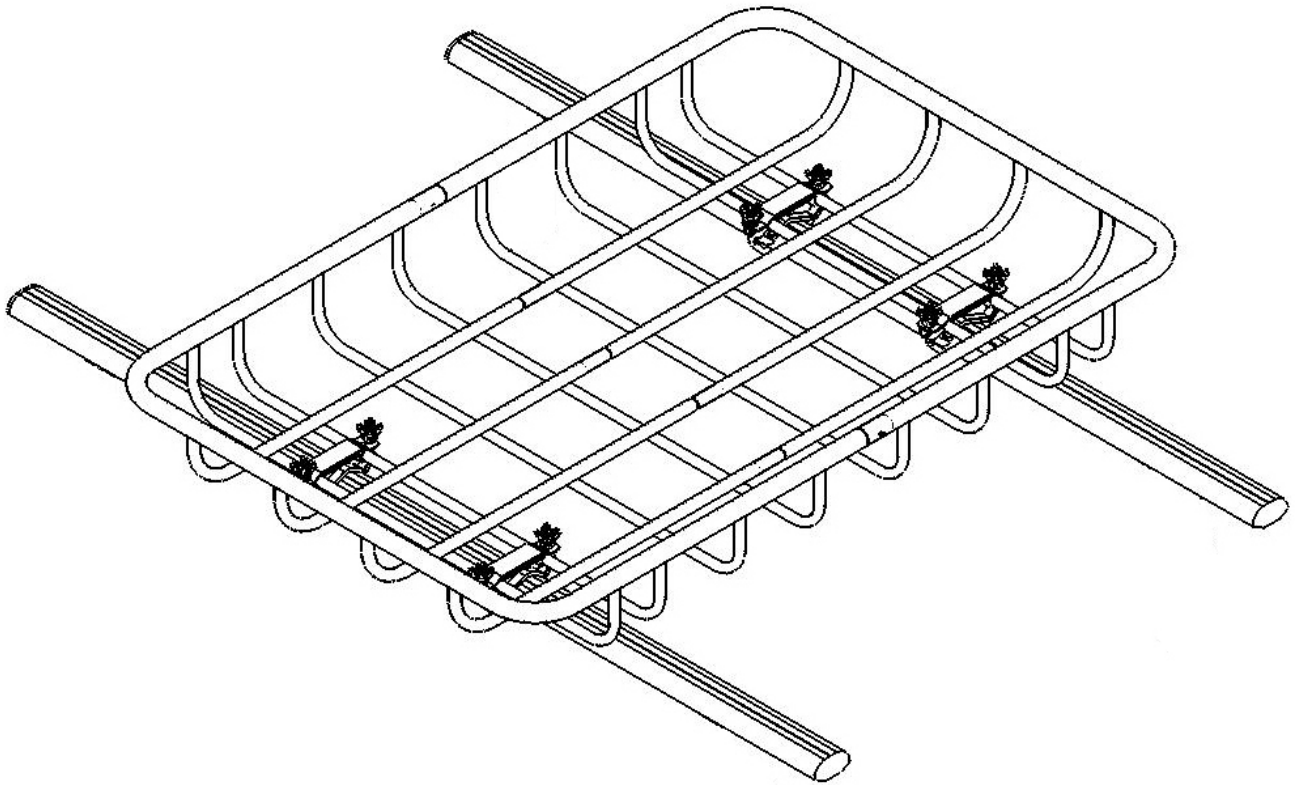

PRO RAC GUIDELINES

Please review the instructions and warranty carefully. Assembly and installation are the purchaser's responsibility and beyond ProRac's control. Therefore, ProRac exclusively limits its warranty to the repair or replacement of a defective ProRac product for up to three years from retail purchase. Warranty excludes damage to your vehicle, cargo, or any person or property during assembly, installation, and use.

- ◆ Do not exceed the load capacity of your rack. Refer to label on crossbar for load limitations. Additionally, follow all vehicle or cap manufacturer load ratings (if applicable). ProRac crossbars do not increase gutter or roof strength.
- ◆ Do not use ProRac crossbars and accessories for purposes other than those for which they were designed. Failure to follow these guidelines or the product instructions will void the warranty.
- ◆ Make sure all knobs, bolts, screws, straps, and locks are firmly attached, tightened, and locked before every trip. All fasteners must be periodically inspected for signs of wear, corrosion, and fatigue. Check your load at stops during long trips to ensure continued fastening security.
- ◆ Check all local and state laws governing projection of objects beyond the width and length of vehicle. Be aware of the width and height of your cargo since low-clearance branches, bridges, and parking garages can affect the load. Never drive with any lock, knob, or rack in an open or unlocked position. All long loads such as, but not limited to, sailboards, surfboards, kayaks, canoes, and lumber must be tied down front and rear to the bumpers or tow hooks of the vehicle.
- ◆ Remove your rack and accessories when they are not in use and before entering automatic car washes.
- ◆ All locks must be turned and moved periodically to ensure smooth operation. Use graphite or similar dry lubricant. Locks are designed to deter vandalism and theft. Remove valuable gear if your vehicle is unattended. Replacement keys are available only through your ProRac dealer.
- ◆ All cargo will affect the vehicle's driving behavior. For your safety, adapt your speed to the conditions of the road and load being carried. Obey all posted speed limits and traffic cautions.
- ◆ Due to their wind resistance, do not carry disks or wheels with covers on the ProRac bike carrier.
- ◆ Consult your ProRac dealer if you have questions regarding the operation and limits of ProRac products. Review all instructions and warranty information carefully.